

Position oben/unten  
Position up/down

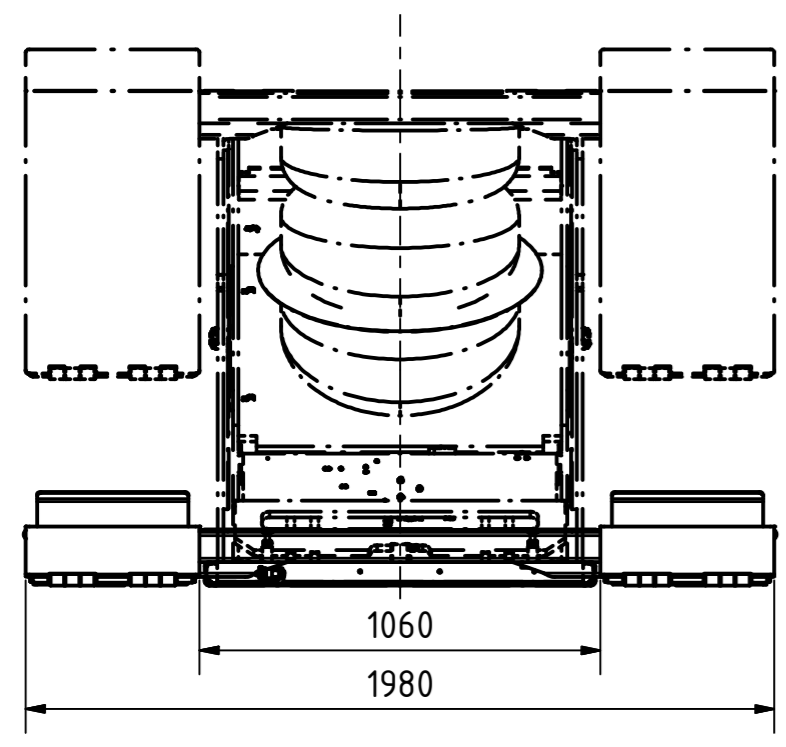

Fahrbahn über die Gummipuffer nivellieren und Gewindestange ggf. kürzen  
Level the platform via the rubber buffers and shorten the threaded bar if necessary.

Position oben/unten  
Position up/down

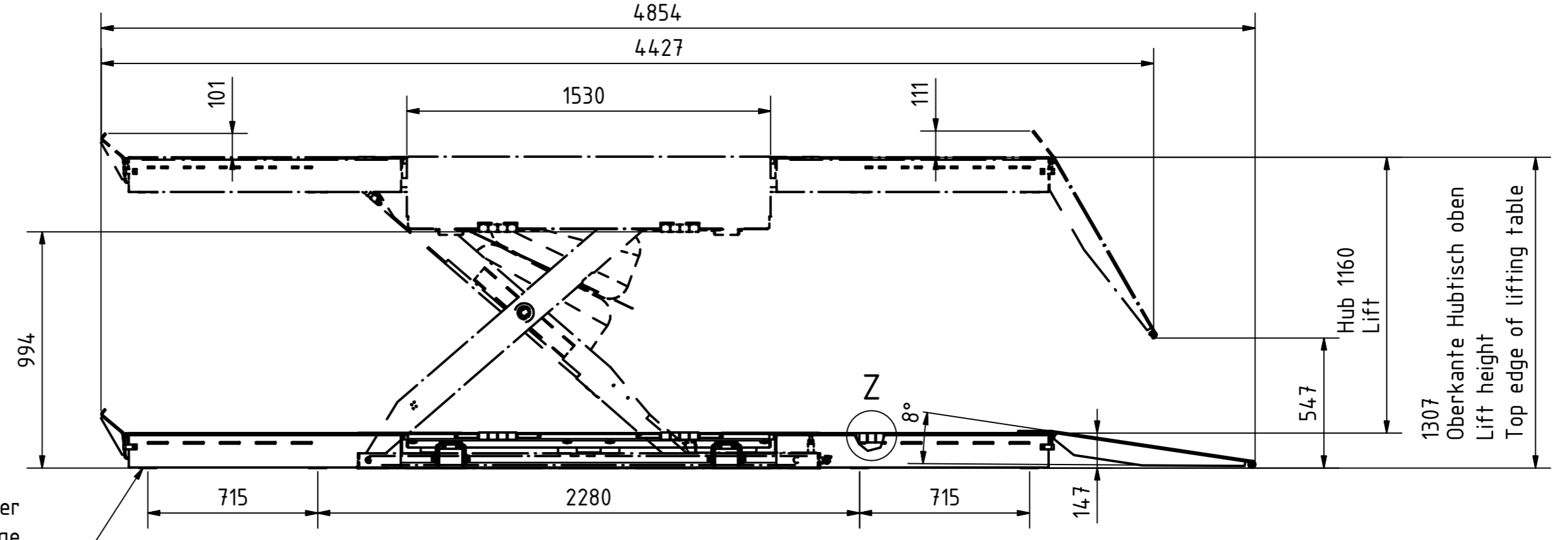

Aufnahme Fahrbahn  
(Symmetrisch)  
Pick-up platform (symmetrical)

Detail Y

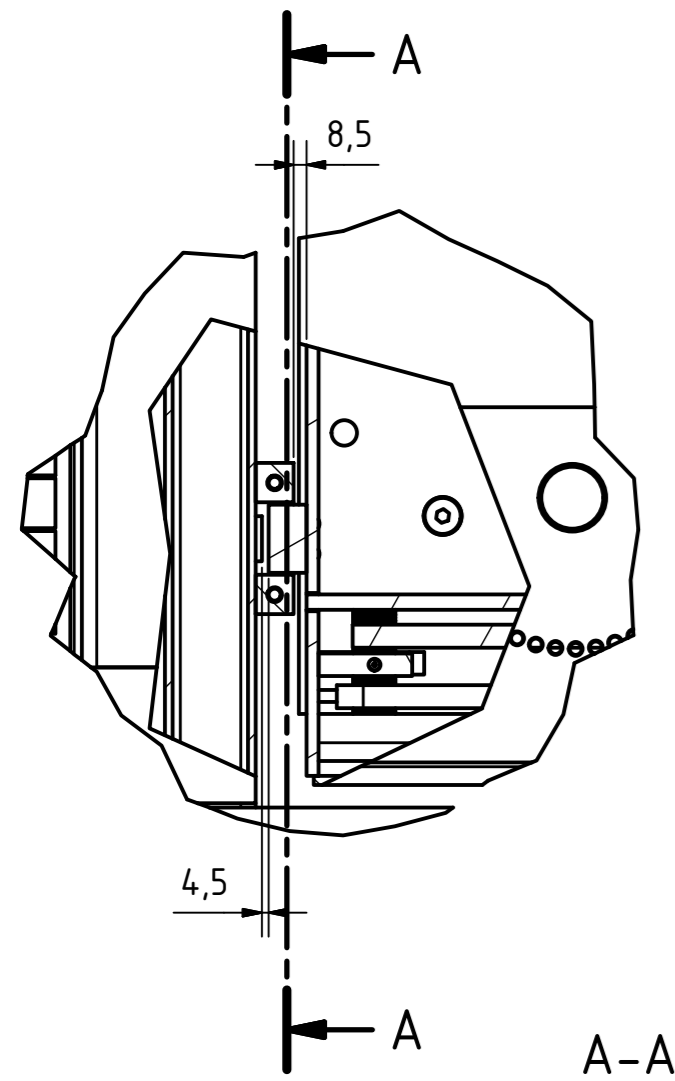

Detail Z

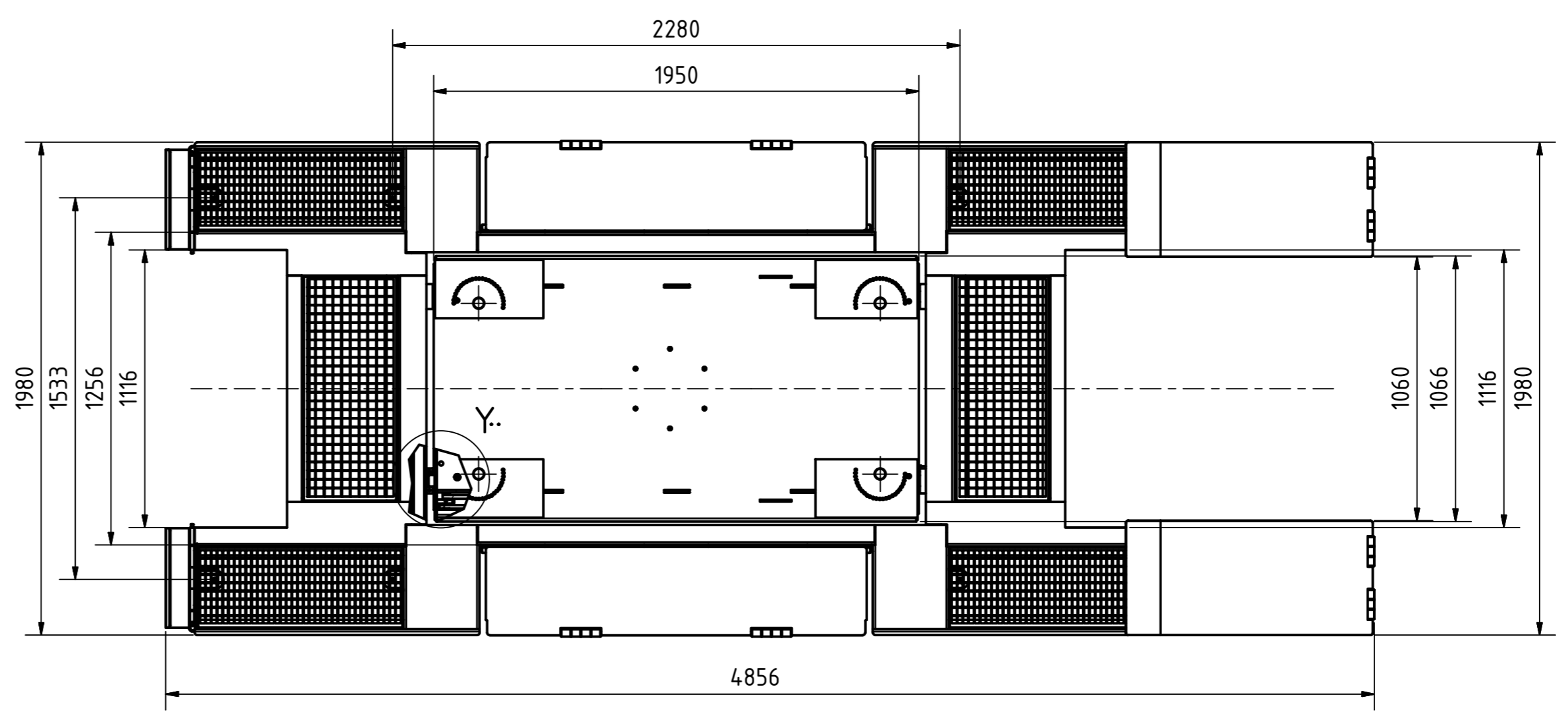
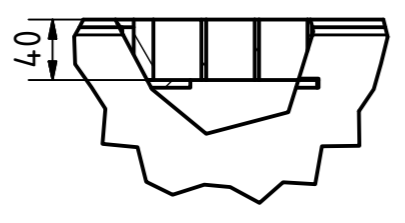

Aus:						Oberfläche DIN ISO 1302	
Maße ohne Toleranzangaben: DIN ISO 2768 mittel							
Änd.	Ind.	Datum	Name	gepr.	Maßstab:	Datum	Name
						gez. 04.04.2022	Falkenroth
						gepr. 04.04.2022	Falkenroth
PL0.35 F BA - P						H509.30-73100.0	
						Ersatz für:	
Ersetzt durch:						von: 3	

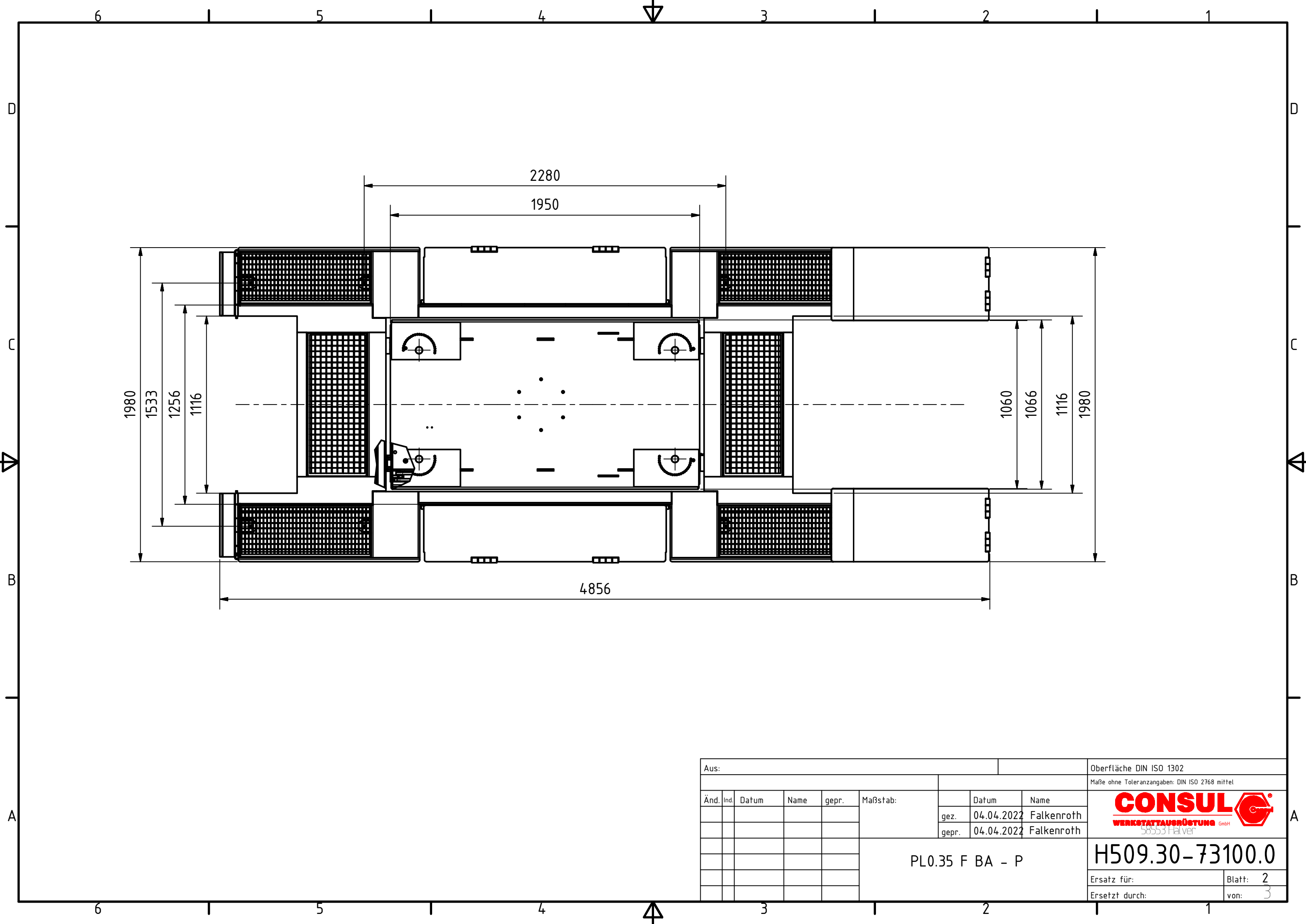

Aus:							Oberfläche DIN ISO 1302			
							Maße ohne Toleranzangaben: DIN ISO 2768 mittel			
Änd.	Ind.	Datum	Name	gepr.	Maßstab:		Datum	Name		
							gez.	04.04.2022 Falkenroth		
							gepr.	04.04.2022 Falkenroth		
									H509.30-73100.0	
									Ersatz für: Blatt: 2	
							Ersetzt durch: von: 3			

PL0.35 F BA - P

H509.30-73100.0

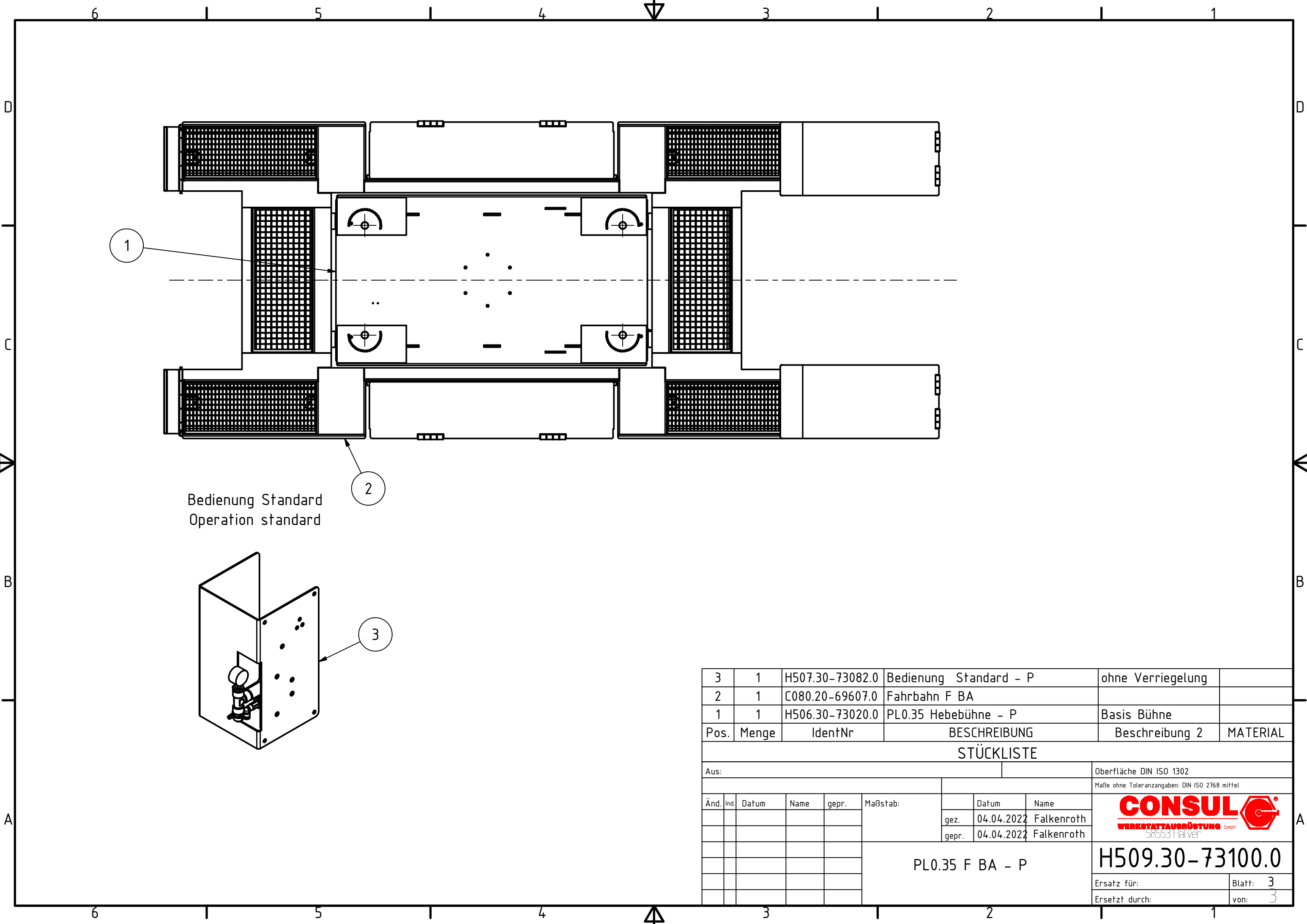

Bedienung Standard  
Operation standard

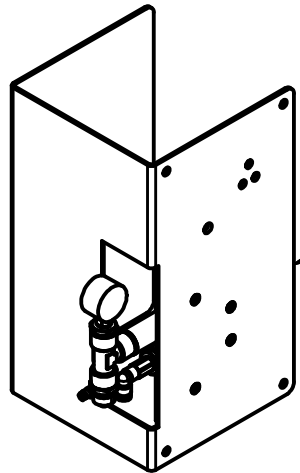

3	1	H507.30-73082.0	Bedienung Standard - P	ohne Verriegelung	
2	1	C080.20-69607.0	Fahrbahn F BA		
1	1	H506.30-73020.0	PL0.35 Hebebühne - P	Basis Bühne	
Pos.	Menge	IdentNr	BESCHREIBUNG	Beschreibung 2	MATERIAL

STÜCKLISTE

Aus:			Oberfläche DIN ISO 1302		
			Maße ohne Toleranzangaben: DIN ISO 2768 mittel		
Änd.	Ind.	Datum	Name	gepr.	Maßstab:
		gez.	04.04.2022	Falkenroth	
		gepr.	04.04.2022	Falkenroth	
					PL0.35 F BA - P
				H509.30-73100.0	
Ersatz für:				Blatt: 3	
Ersetzt durch:				von: 3	

