

[www.cemb.com](http://www.cemb.com)



since 1997

**RONDO**

[www.rondodoo.hr](http://www.rondodoo.hr)

# SM615

## bike



### MOTORCYCLE TYRE CHANGER

### SMONTAGOMME PER MOTOCICLI



# CEMB

GARAGE EQUIPMENT

# SM615 bike



- Semi-automatic tyre changer with **swing arm**, vertical working arm with lever lock, side positioning of the tool with respect to the rim by means of a knob and **vertical working arm with spring return**. Fastening of the horizontal arm on the post has been designed to allow operating on wheels with rim size from 3.6 to 22 inch (typical of motorcycles, karts, ATV wheels and hobby and gardening machines).

- Smontagomme semiautomatico con **palo a bandiera**, bloccaggio a leva dell'asta verticale, posizionamento laterale dell'utensile rispetto al cerchio tramite manopola e con **ritorno a molla dell'asta verticale**. Il fissaggio del braccio orizzontale sulla colonna è stato progettato per consentire di operare su ruote con cerchi da 3.6 a 22 pollici (tipiche di motocicli, kart, route ATV e macchine per hobbistica e da giardino).

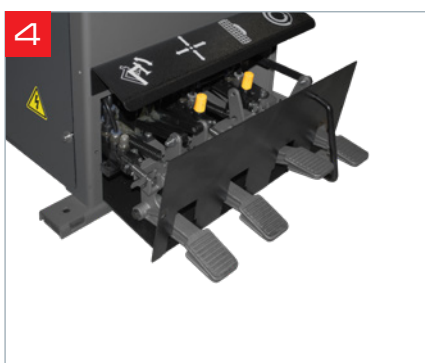

- Body with **extractable pedal unit** to facilitate technical service, **robust reduction unit**, standard CE-certified inflation pressure limiter with provision for gun connection.

- Carcassa con **pedaliera estraibile**, che facilita l'assistenza tecnica, **robusto riduttore**, limitatore pressione di gonfiaggio a norme CE di serie e già predisposto al collegamento della pistola.



Semi-automatic tyre changer with horizontal moving arm, suitable for motorcycle wheels with a rim size from 3.6" to 22".

Smontagomme semi-automatico con braccio mobile orizzontale, progettato per lavorare su ruote di motocicli con un diametro del cerchio compreso tra 3.6" e 22".

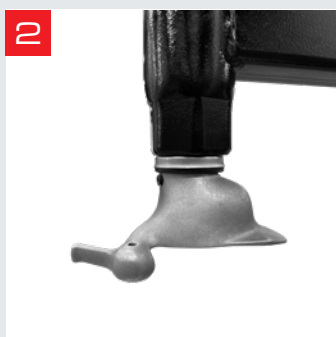

- **Mounting head** for motorcycle wheels.
- **Testina di smontaggio** specifica per ruote di motocicli.



- **Self-centring plate** with 3.6"- 22" locking capacity.
- **Piatto autocentrante** con capacità di bloccaggio 3.6"- 22".

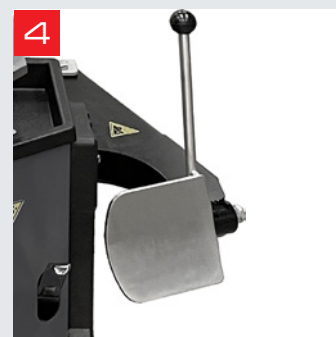

- **Bead breaker** for motorcycle wheels with **double-acting cylinder and fixed blade**.
- **Stallonatore** per ruote moto con **cilindro a doppio effetto e paletta fissa**.



## STANDARD EQUIPMENT - ACCESSORI STANDARD

The machine is supplied standard with plastic protections for mounting head and for bead lifter lever to operate correctly on alloy rims.

Macchina fornita di serie di protezioni plastiche per testina di montaggio e leva per operare correttamente sui cerchi in lega.

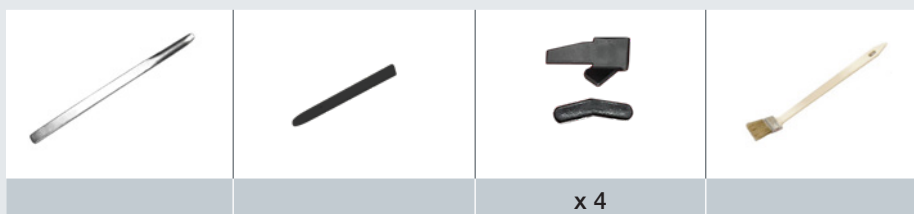

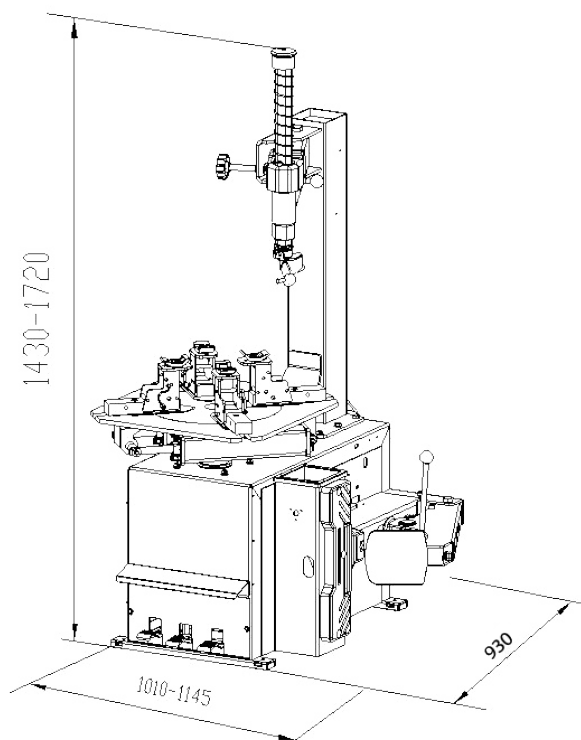

Clamping capacity	Capacità di bloccaggio	3.6" - 22"
Max wheel diameter	Diametro massimo ruota	1000 mm (39.5")
Max wheel width	Larghezza massima ruota	270 mm (10")
Bead breaker force	Forza stallonatore	3000 kgf
Operating pressure	Pressione di esercizio	10 bar (147 psi)
Power supply	Alimentazione	230V / 50Hz / 1ph
Motor power	Potenza motore	0.75kW
Noise lever in working conditions	Livello di rumore in condizioni di lavoro	< 70 dB (A)
Max. spindle torque	Massimo momento torcente	1200 Nm
Max. intake pressure	Massima pressione aria in ingresso	10 bar (145 psi)
Max. inflating pressure	Massima pressione di gonfiaggio	3.5 bar (50 psi)
Relief valve on inflating device	Valvola di sicurezza sul dispositivo di gonfiaggio	4 bar (58 psi)
Net weight	Peso netto	230 kg
Packing dimensions	Dimensioni imballo	760 x 975 x 950 mm



**CEMB**  
BALANCING MACHINES

CEMB S.p.A.

Via Risorgimento, 9  
23826 Mandello del Lario (LC) - Italy  
[www.cemb.com](http://www.cemb.com)



Garage equipment division  
CEMB - ITALY  
Plant and Training Center  
Phone +39 0341 706111  
[garage@cemb.com](mailto:garage@cemb.com)

**SIPAV**

Distributore esclusivo per l'Italia:

Via A. Nobel, 21 - 42124 Sesso (RE)  
Tel. 0522. 532.711 - Fax 0522.531.828  
[sipav@sipav.com](mailto:sipav@sipav.com) - [www.sipav.com](http://www.sipav.com)



since 1997

**RONDO**

[www.rondodoo.hr](http://www.rondodoo.hr)

All the data and features mentioned in this catalogue are purely for information and do not constitute any commitment on the part of our company, which reserves the right to make any and all alterations it may consider suitable without notice.