

EINZELHEIT E

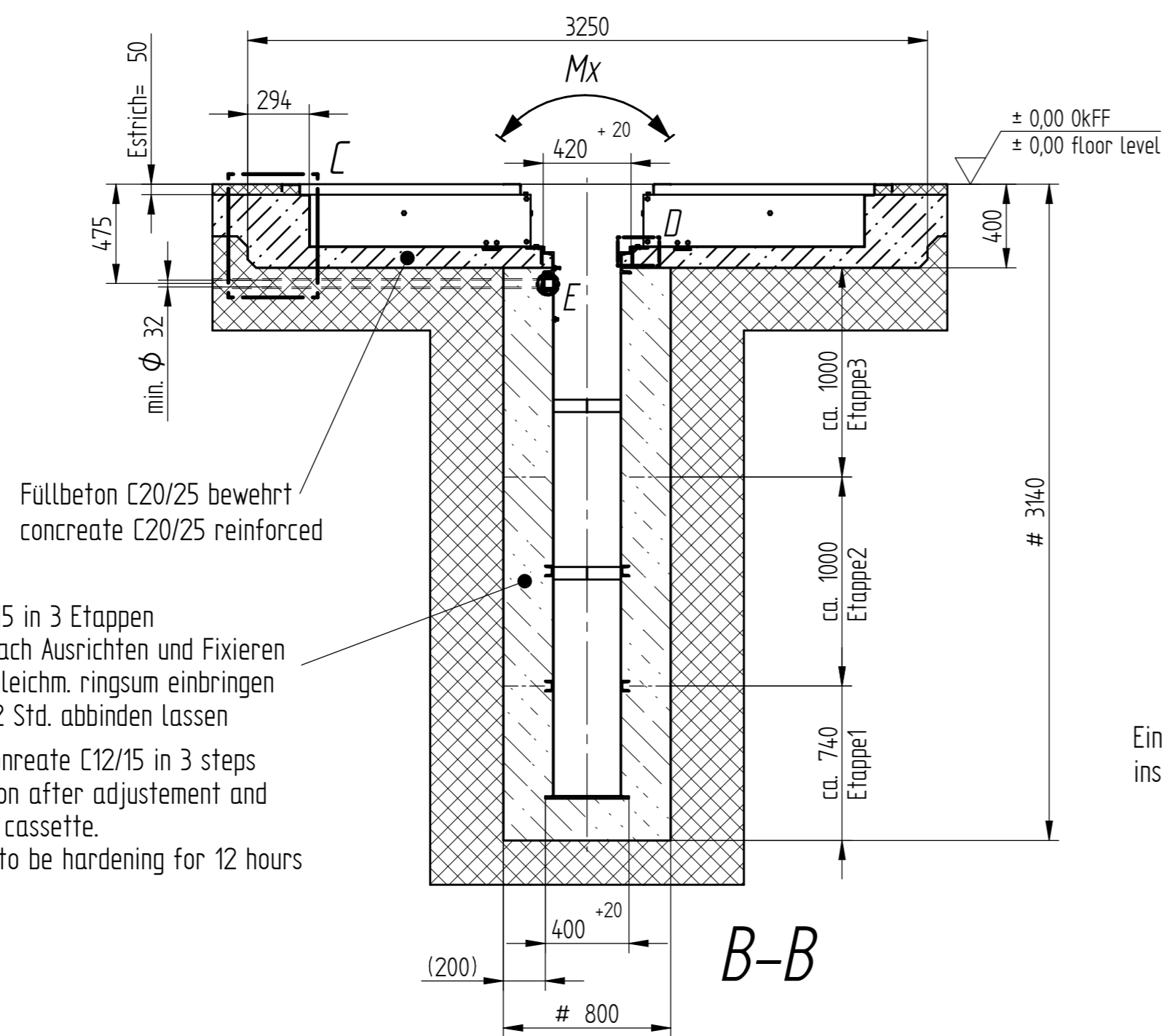

B-B

Füllbeton C12/15 in 3 Etappen ohne Rüttler nach Ausrichten und Fixieren der Kassette gleichm. ringsum einbringen. Jede Etappe 12 Std. abbinden lassen. fill in filling concrete C12/15 in 3 steps without vibration after adjustment and fixation of the cassette. in every steps to be hardening for 12 hours

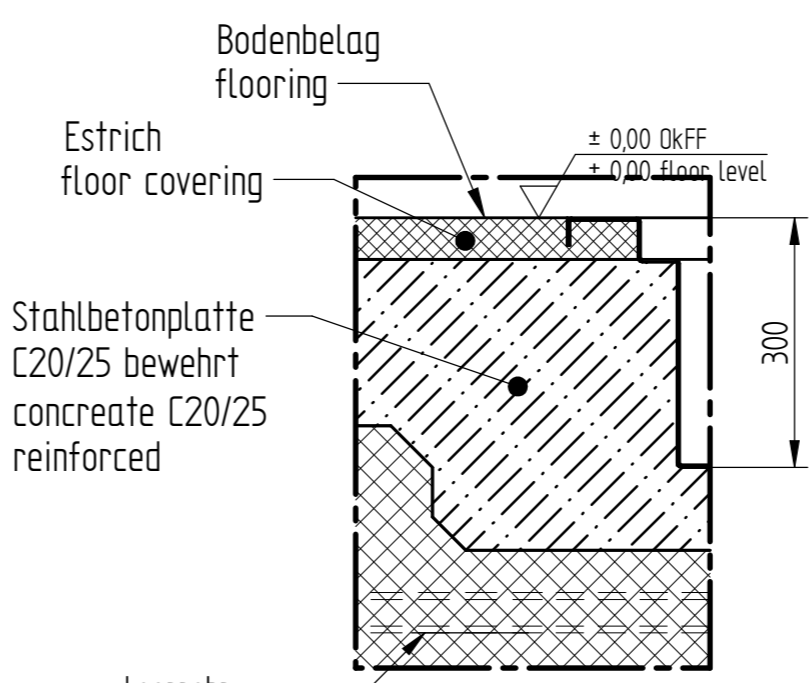

EINZELHEIT C

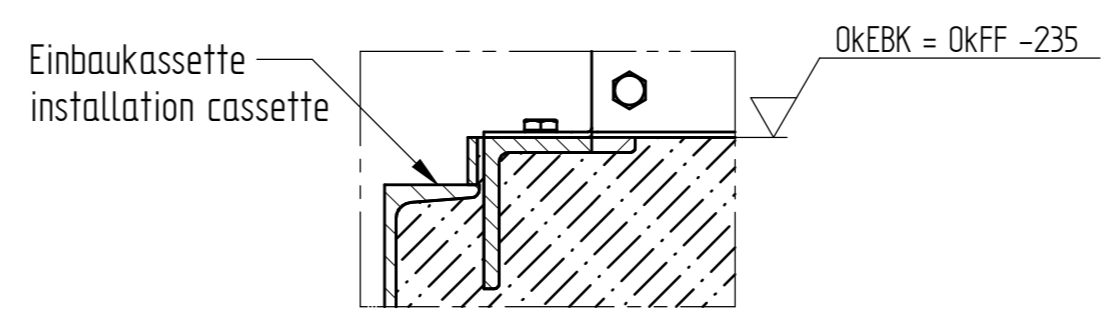

EINZELHEIT D

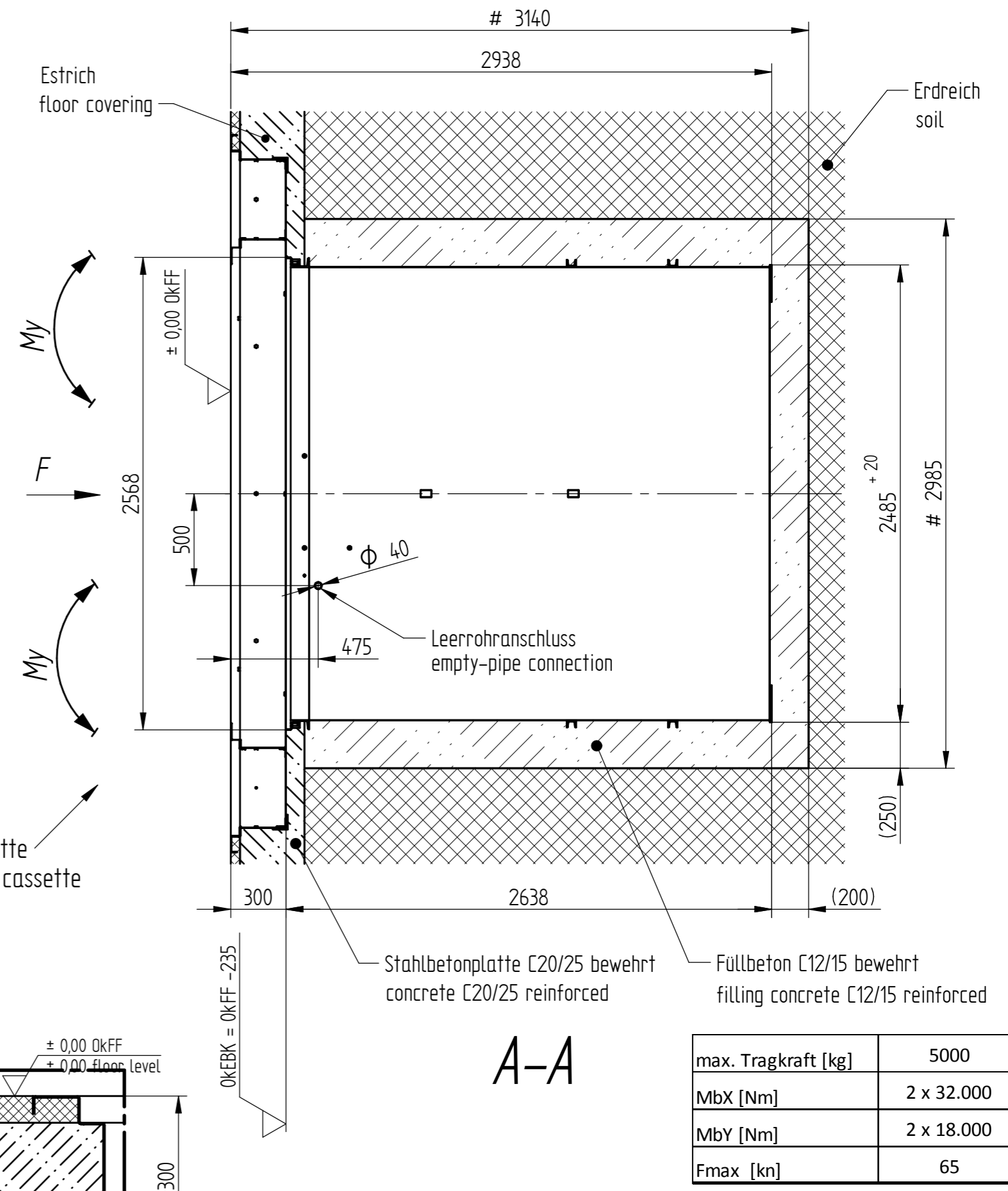

A-A

Aufnahme Swingarm 2.50
 Alle Maße sind Mindestmaße in mm
 all dimension are minimum in mm
 Stempelabstand 2285 (5,0t)
 piston distance 2285 (5,0t)
 # = Mindestmaß, sonst nach Bodenbeschaffenheit
 # = minimum, otherwise acc. to foundation requirements

<p>Herrmann AG Bahnhofstr. 32 93483 Posing</p>	Zeichnungsnummer	FP2285-F-300-SA5t
	Stand	18.01.22 Zst. 0
Fundamentplan Swingarm SA2285 flureben		
Foundation plan swingarm SA2285 floor level		