

* BMW A=3500 / B=2600

* 5 to A=3000 / B=2500
bzw. A=3500 / B=2500

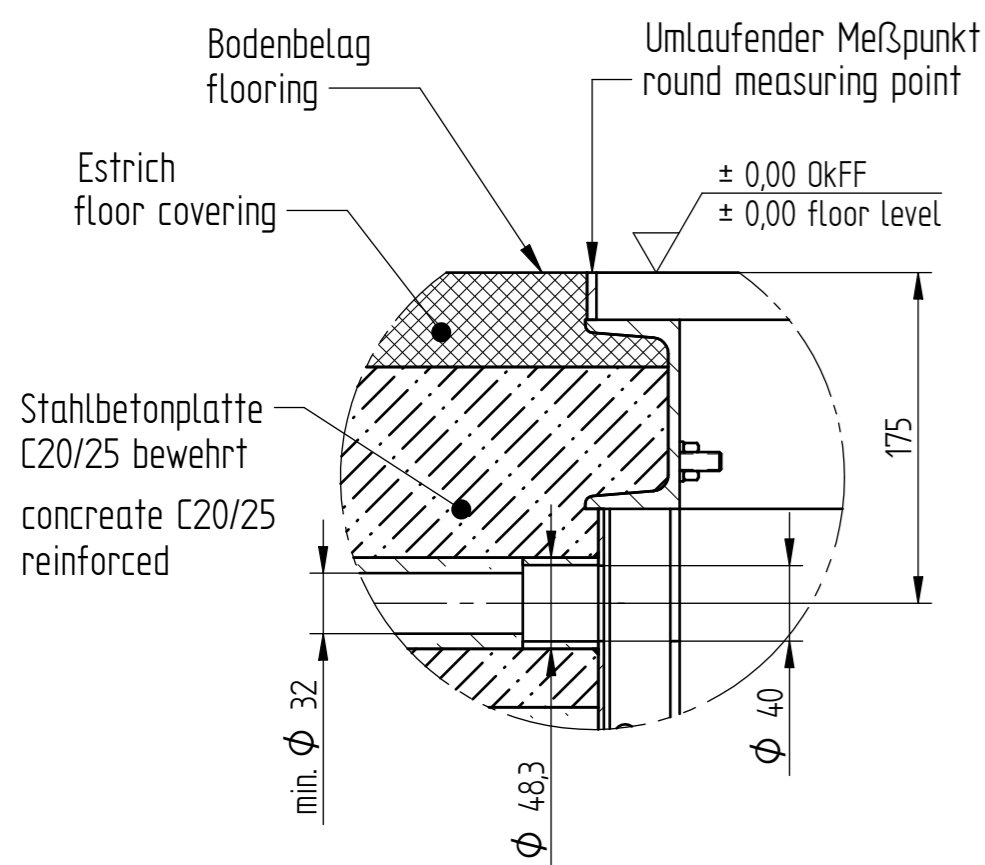

EINZELHEIT C

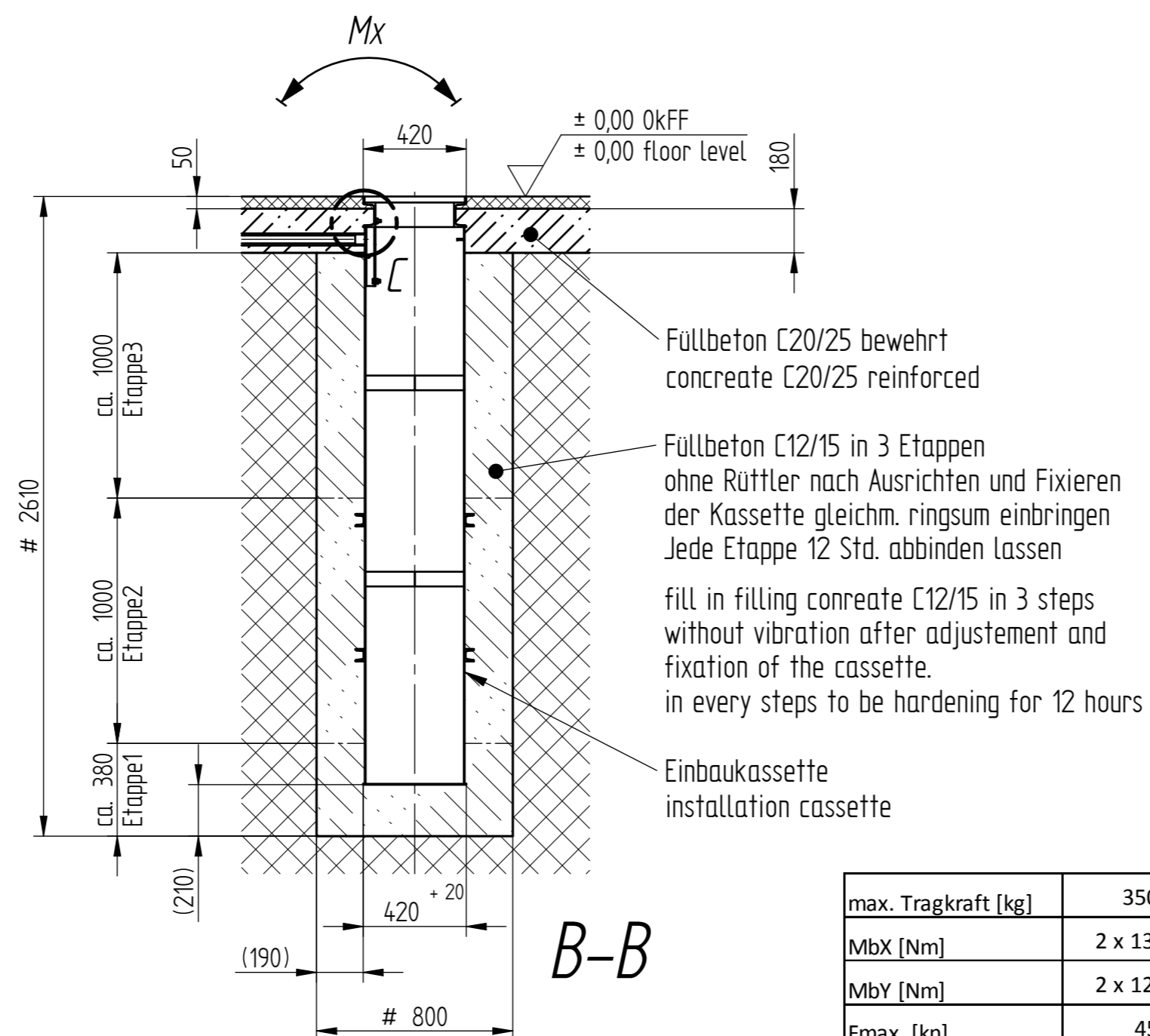

B-B

A-A

Alle Maße sind Mindestmaße in mm
all dimension are minimum in mm

Stempelabstand 2285 (3,0t/3,5t/5,0t/6,5t)
piston distance 2285 (3,0t/3,5t/5,0t/6,5t)

= Mindestmaß, sonst nach Bodenbeschaffenheit
= minimum, otherwise acc. to foundation requirements

max. Tragkraft [kg]	3500	5000	6500
MbX [Nm]	2 x 13.500	2 x 31.000	2 x 41.500
MbY [Nm]	2 x 12.500	2 x 18.000	2 x 23.000
Fmax [kn]	45	65	85

HERRMANN
Herrmann AG | Bahnhofstr. 32 | 93483 Posing

Zeichnungsnummer

FP2285 H2408

Fundamentplan SA2285
Foundation plan SA2285

Stand
12.12.19
Zst. 0