

Leerrohranschluss DN32 zur Hebebühnensteuerung
(nur ein Anschluss benötigt)
idle pipe DN32 to the site of control unit
(only one connection required)

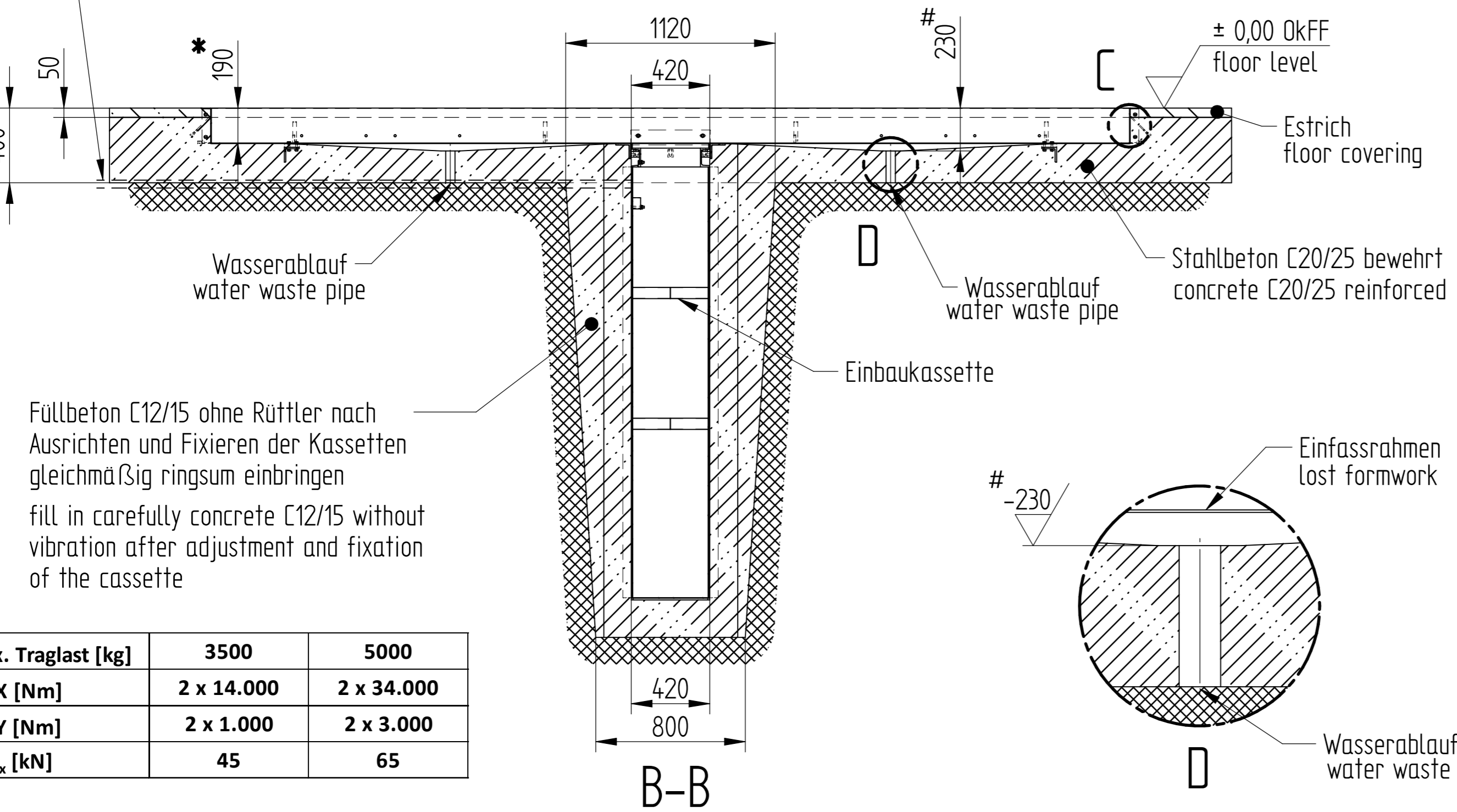

Füllbeton C12/15 ohne Rüttler nach Ausrichten und Fixieren der Kassetten gleichmäßig ringsum einbringen
fill in carefully concrete C12/15 without vibration after adjustment and fixation of the cassette

max. Traglast [kg]	3500	5000
MbX [Nm]	2 x 14.000	2 x 34.000
MbY [Nm]	2 x 1.000	2 x 3.000
F _{max} [kN]	45	65

± 0,00 OkFF floor level
A-A Füllbeton C12/15 bewehrt
concrete C12/15 reinforced
Stahlbeton C20/25 bewehrt
concrete C20/25 reinforced

± 0,00 OkFF floor level

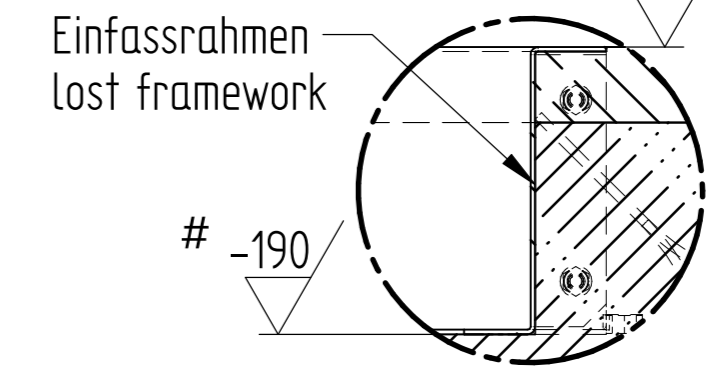

= Maß von OkFF gemessen!
= measured from floor level!

* Rahmenhöhe = 190 mm
frame height = 190 mm

Alle Maße sind Mindestmaße in mm
all dimension are minimum in mm

<p>Herrmann AG Bahnhofstr. 32 93438 Pöding</p>	Zeichnungsnummer
	FP10053-FQ
<p>Fundamentplan Fahrbahn Alu-Track flureben ohne Bodenniveaueausgleich foundation plan flush-mounted inground platforms Alu-Track-System, without floor equalization</p>	Stand
	28.10.16