

A-A

Alle Maße sind Mindestmaße in mm
all dimension are minimum in mm

Stempelabstand 2530 (Ölhydraulik)
piston distance 2530 (oil hydraulics)

= Mindestmaß, sonst nach Bodenbeschaffenheit
= minimum, otherwise acc. to foundation requirements

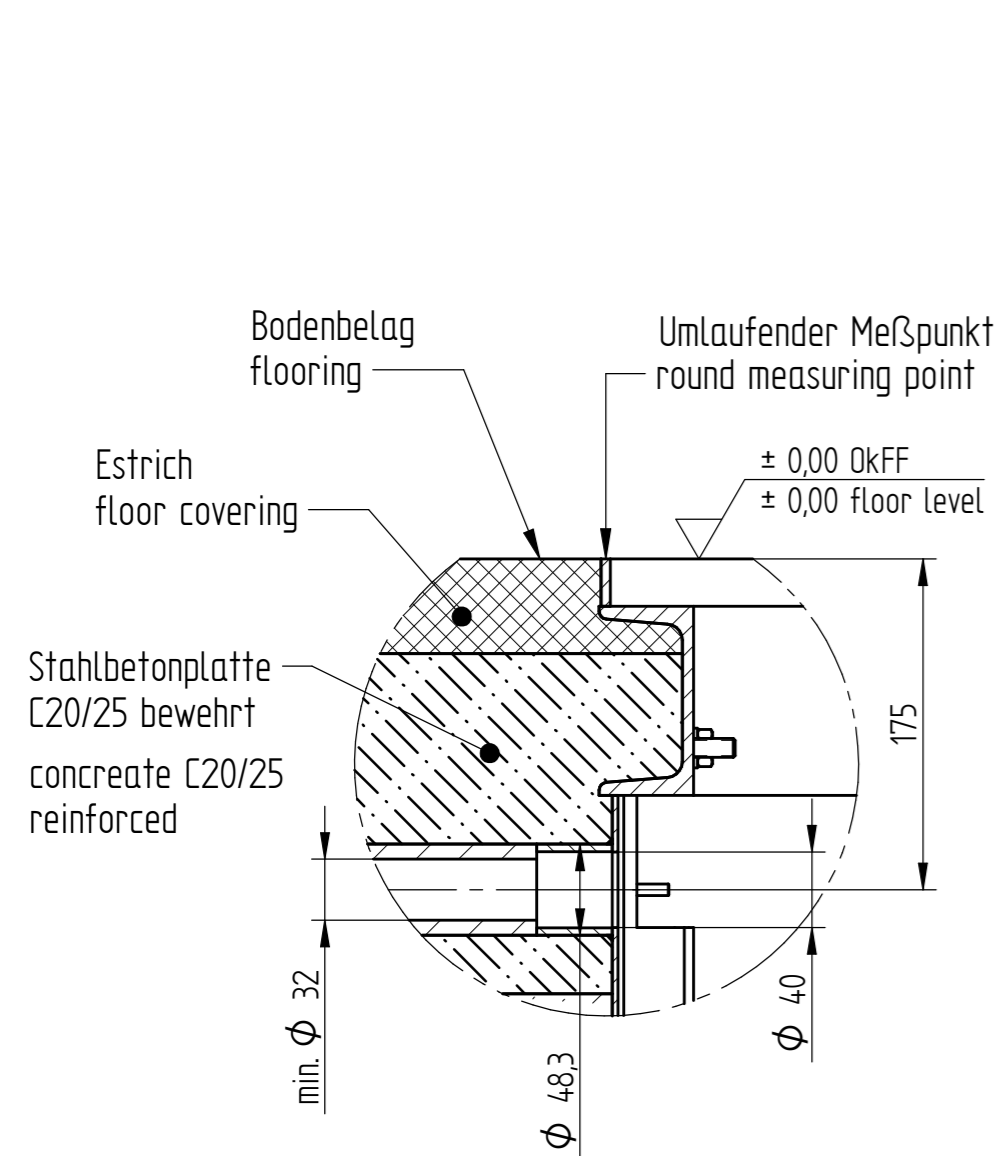

INZELHEIT C

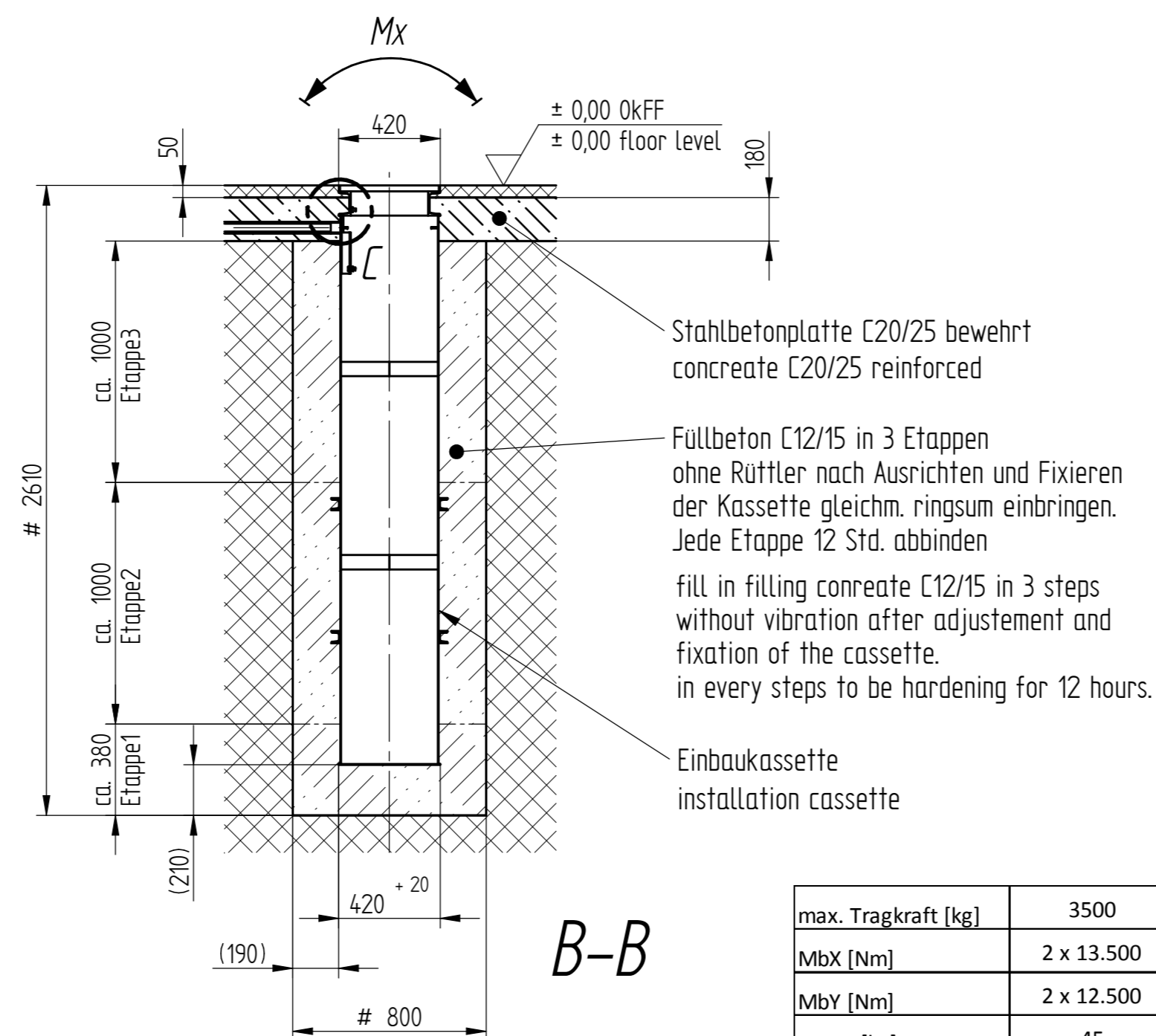

B-B

max. Tragkraft [kg]	3500	5000	6500
MbX [Nm]	2 x 13.500	2 x 31.000	2 x 41.500
MbY [Nm]	2 x 12.500	2 x 18.000	2 x 23.000
Fmax [kn]	45	65	85

<p>Herrmann AG Bahnhofstr. 32 93483 Posing</p>	Zeichnungsnummer	FP2530 H2408
	Stand	01.07.21
Fundamentplan SA2530	Zst. 0	
Foundation plan SA2530		