

FLUSH MOUNTED

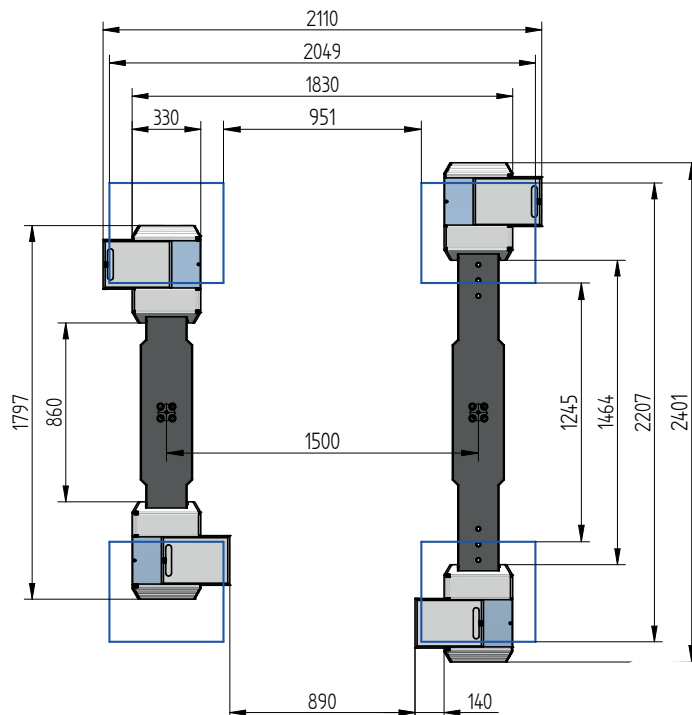
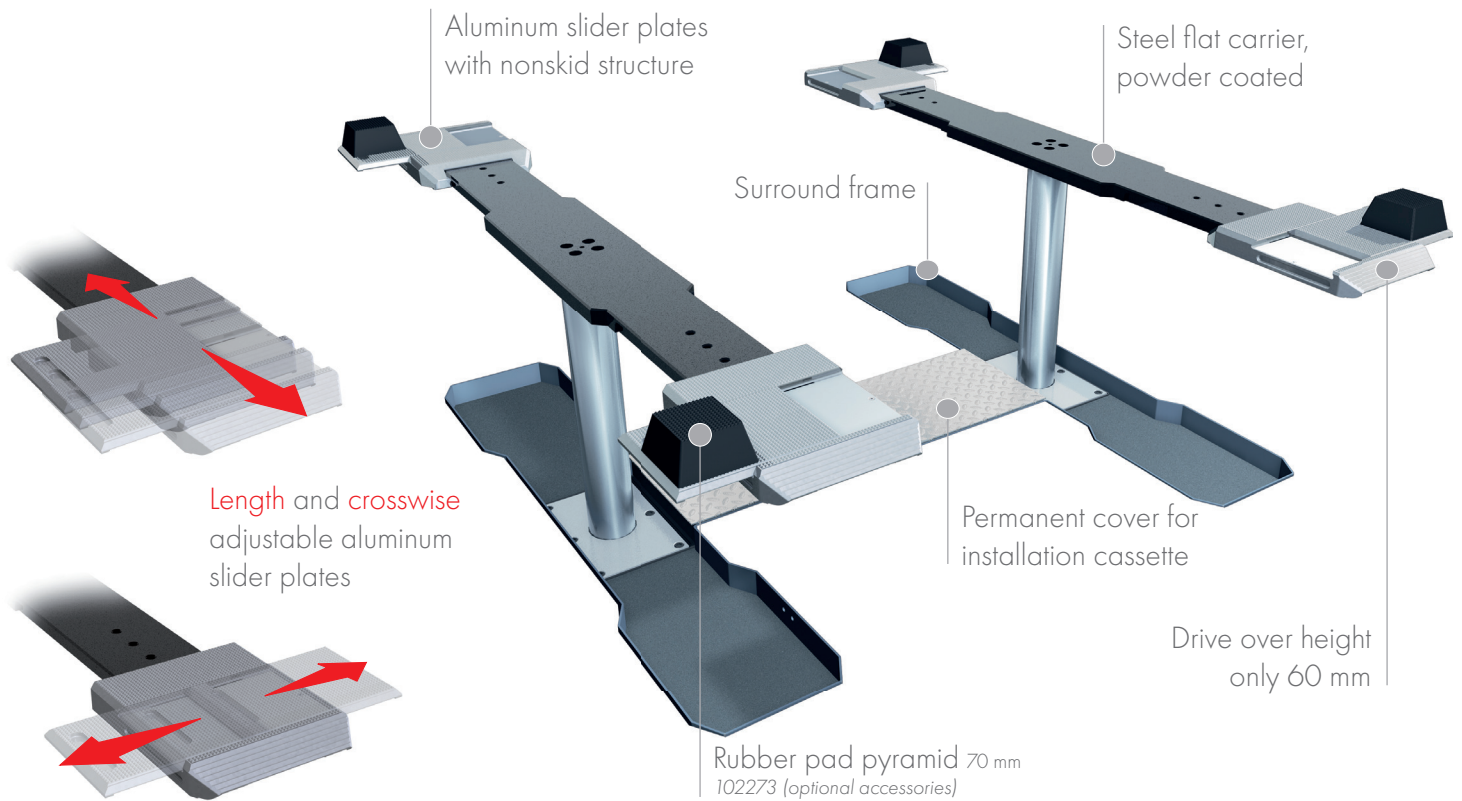

TECHNICAL DATA

Capacity	3500 kg
Effective raise height	2023 mm
Drive over height	60 mm
Piston diameter	123 mm
Piston distance	1500 mm
Installation depth	2408 mm
Motor output	3,0 kW
Power connector	400 V/16 A
Cable length to control	11 m
Lifting time	≈ 35 sec.
Lowering time	≈ 35 sec.

Support Uni 2.35 plus maxi	102642
Support Uni 2.35 plus maxi galvanized	105225
Installation cassette STEEL 1500 mm	2260XX
Installation cassette STEEL 1500 mm galvanized	2261XX
Lifting unit oil 3,5 t 1500 mm - K pre-assembled in installation cassette	109965
Lifting unit oil 3,5 t 1500 mm - H packed in wooden box	109977
Surround frame Uni plus maxi 1500	109602

ACCESSORIES

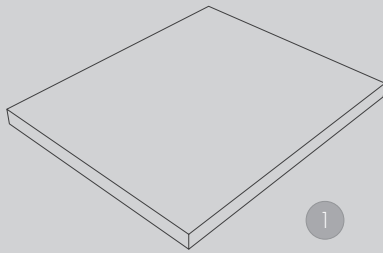

1

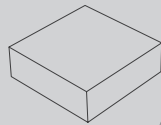

2

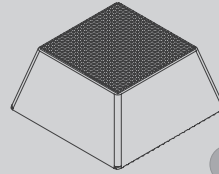

3

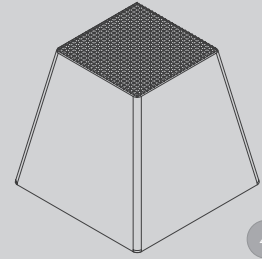

4

1 Rubber pad
290 x 335 x 20 mm
102275 (1 Set / 4 Pieces)

2 Rubber pad
120 x 120 x 40 mm
102274 (1 Set / 4 Pieces)

3 Rubber pad pyramid
70 mm
102273 (1 Set / 4 Pieces)

4 Rubber pad pyramid
140 mm
102291 (1 Set / 4 Pieces)

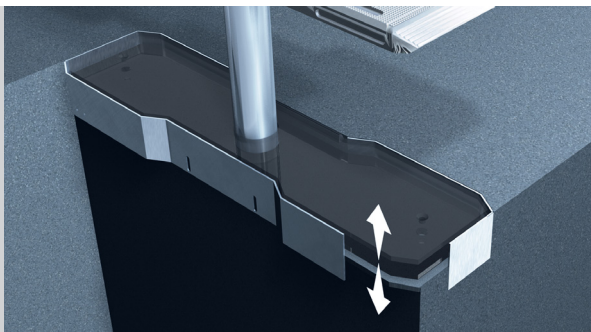

Floor compensation Uni plus maxi
powder coated
109603

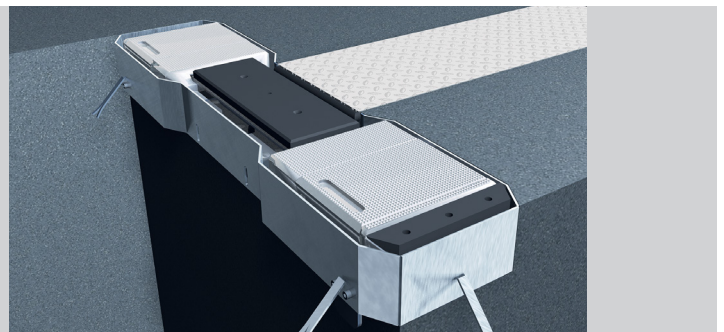

Levelling plates Uni plus midi
for flat surface of the carriers
110340 (1 Satz / 2 Stück)

Levelling wedges Uni plus
for flat surface of the slider plates
109605 (1 Satz / 2 Stück)

Herrmann AG
Bahnhofstrasse 32
D-93483 Pöding

Phone: +49 (0)9461/91388 50
E-Mail: sales@herrmann-lifts.com

www.herrmann-lifts.com