

* 5 to A=3500 / B=2600

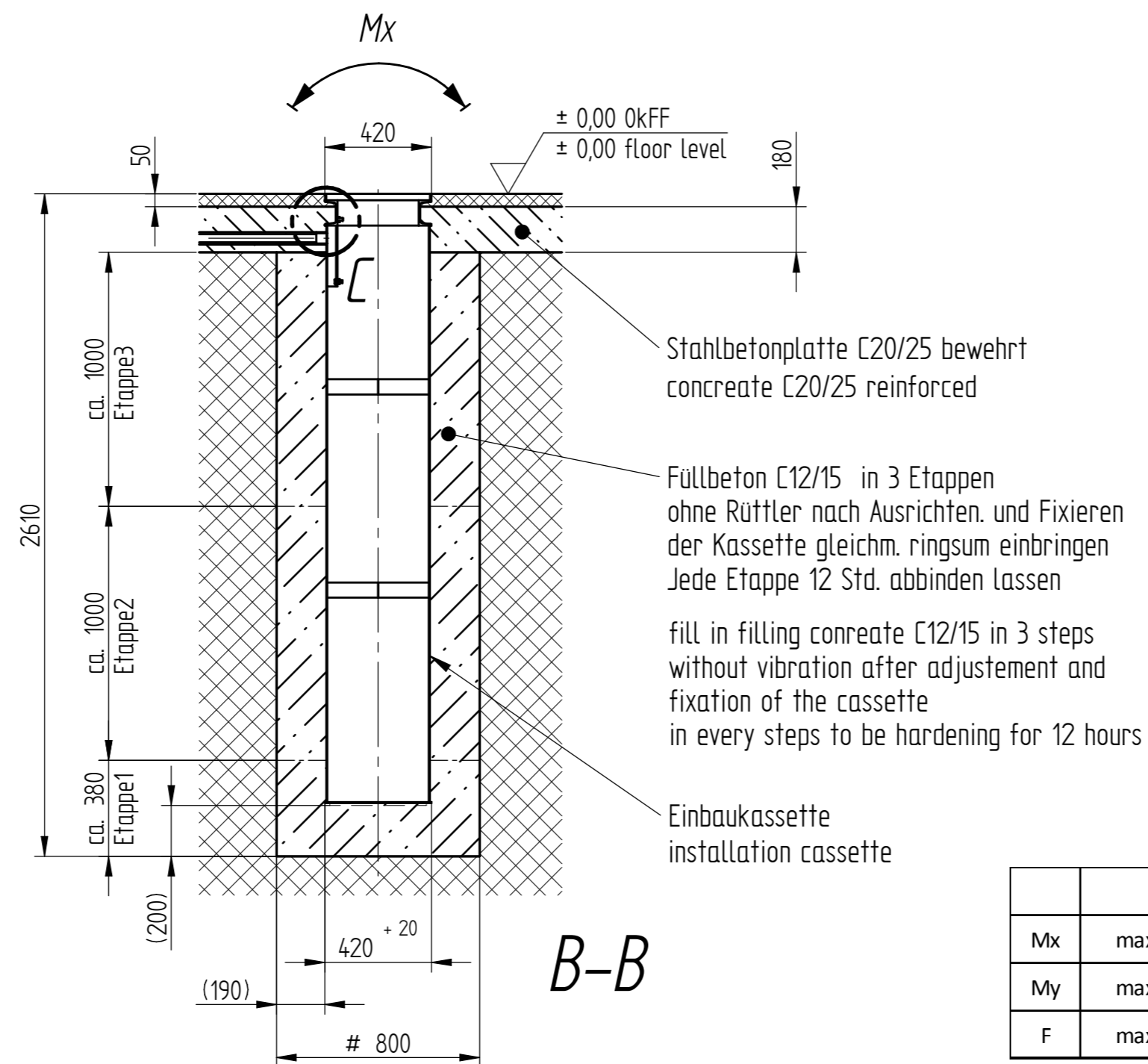
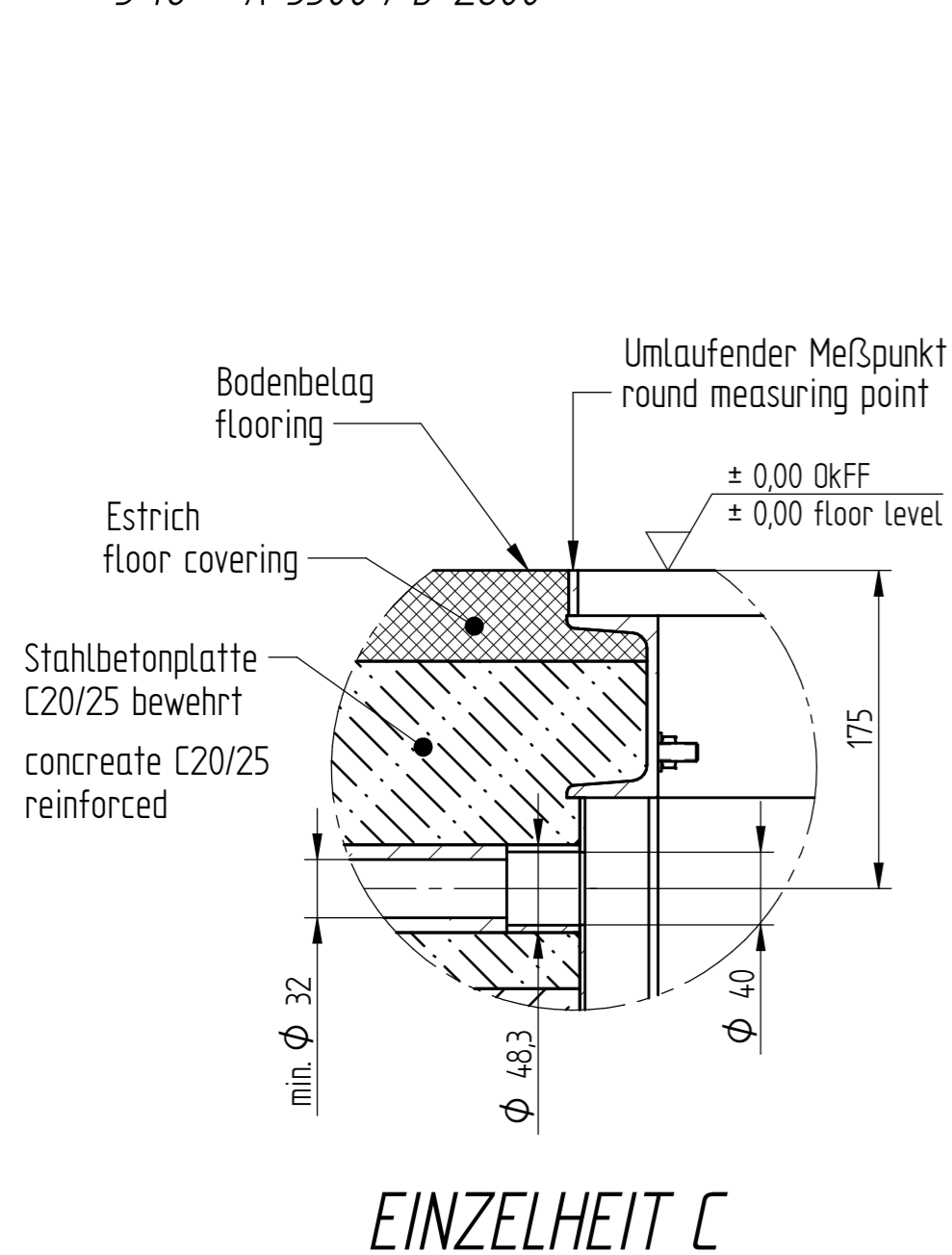

A-A

Alle Maße sind Mindestmaße in mm
all dimension are minimum in mm

Stempelabstand 1500 (3,5t/5,0t)
piston distance 1500 (3,5t/5,0t)

= Mindestmaß, sonst nach Bodenbeschaffenheit
= minimum, otherwise acc. to foundation requirements

	3,5 t	5,0 t
Mx	max. 30 kNm	max. 45 kNm
My	max. 20 kNm	max. 30 kNm
F	max. 45 kN	max. 65 kN

<p>Herrmann AG Bahnhofstr. 32 93483 Posing</p>	Zeichnungsnummer	FP1500 H2408
	Stand	11.12.19
Fundamentplan SA1500		Zst. 0
Foundation plan SA1500		